

The S80 Controller allows you to control digital LED strips (pixels) using a radio remote control or the R240 Wi-Fi bridge. The controller has over 110 built-in effects and allows for zone control (independent control of multiple receivers with a single remote). Thanks to the built-in microphone, the device responds to sound. The device supports all ICs (integrated circuits) on digital strips and all strip types (RGB, RGBW, CCT, MONO, RGB+CCT).

Strip type	Maximum number of pixels	Maximum strip length [m]		
		60d/m 24V	60d/m 12V	30d/m 12V
RGB	1000	100	50	100
RGBW SK6812	700	70	35	70
RGBW TM1814	700	70	35	70
CCT WS2811	1000	100	50	100
CCT TM1814	700	70	35	70
MONO	1000	100	50	100
RGB+CCT WS2805	600	60	30	60
RGB+CCT WS2811	500	50	25	50

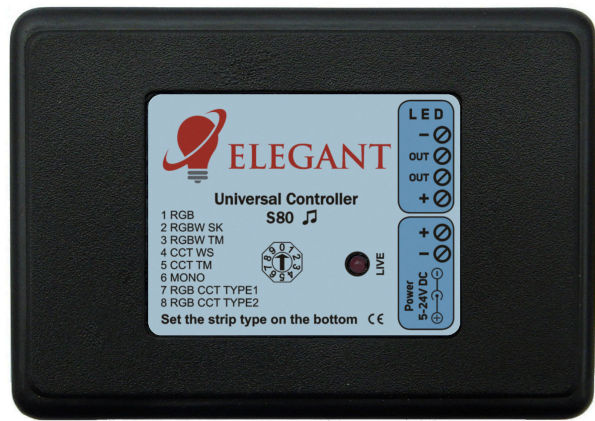

STANDARD CONNECTION

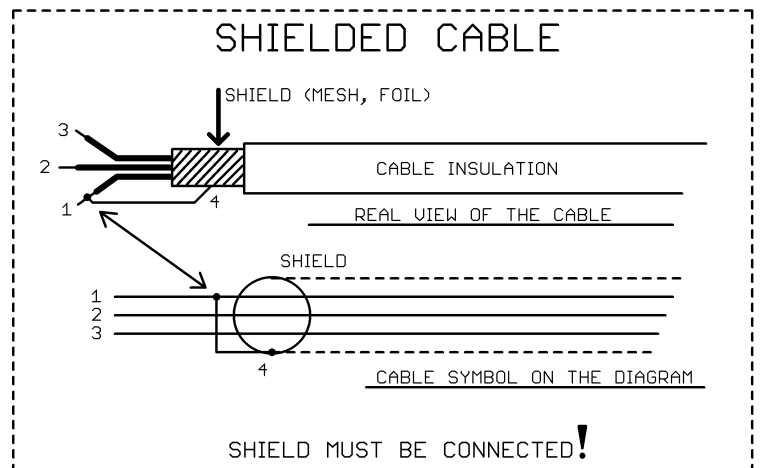
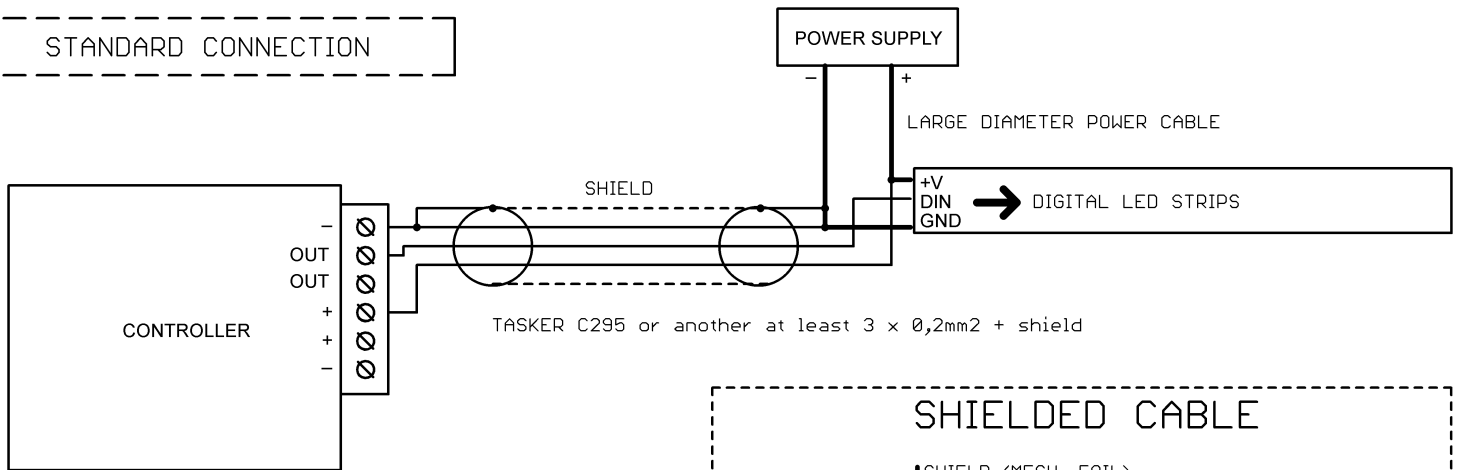

CONNECTION IN THE CASE OF FOUR-WIRE STRIPS (WS2813, WS2815, WS2818)

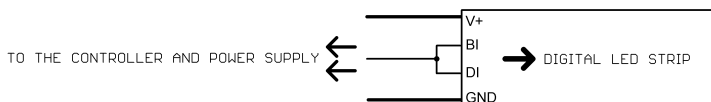

Configuration for RGB, RGBW, RGB+CCT strips

Step 1: Selecting the LED strip

Before starting the configuration, use a screwdriver to set the switch on the bottom of the controller to the desired LED strip type:

1. RGB	2. RGBW SK	3. RGBW TM	4. CCT WS	5. CCT TM	6. MONO	7. RGB+CCT TYPE 1	8. RGB+CCT TYPE 2
--------	------------	------------	-----------	-----------	---------	----------------------	----------------------

Step 2: Pairing the remote control with the controller (mandatory)

Each controller can be assigned a specific remote control and a specific zone (Fig. 1, buttons 5.). If this is not done, the controller will not respond to the remote control. To do this, follow these steps:

- Connect the digital LEDs to the controller
- Turn on the controller's power and within 2 seconds of powering on, briefly press "M", and then "I" on one selected zone switch (5.). The LEDs should blink.

The controller can also be configured using the R240 Wi-Fi bridge by pairing it with a zone, then selecting "Controller configuration" in the "Edit the zone" menu and adjusting the parameters in the window. If both a remote and the bridge are used, the remote must be paired with the bridge. Remote pairing can be found in the Settings menu (gear icon in the top right corner).

Step 3: Configuration mode

To enter the configuration settings, long press the "M" button (8 seconds).

Step 4: Color order

After entering configuration mode, the LEDs at the beginning of the LED strip should light up. Now, use the "S+" and "S-" buttons to set the first three LEDs to light in the following colors: red, green, and blue.

- Press the "M" button to proceed to the next step.

Step 5: Strip length

To set the desired LED strip length, use the "S+" and "S-" buttons to fill the entire LED strip with lit sections, ensuring that the flashing section reaches the end of the LED strip. To speed up this process, use the "I" and "O" buttons on the SECOND zone switch. In this case, you will light up 10 sections at a time, instead of one at a time.

- Press the "M" button to proceed to the next step.

Step 6: Turning off the microphone

You can disable the microphone in the controller. If the LED strip's beginning lights up, it means the microphone is enabled.

- Use the "S+" button to turn the microphone on or off.
- Use the "M" button to exit the configuration.

Configuration for CCT and MONO strips

Step 1: Selecting the LED strip

Before starting the configuration, use a screwdriver to set the switch on the bottom of the controller to the desired LED strip type:

1. RGB
2. RGBW SK
3. RGBW TM
4. CCT WS
5. CCT TM
6. MONO
7. RGB+CCT WS2805 TYPE 1
8. RGB+CCT WS2811 TYPE 2

SUPPORTED REMOTE CONTROLS::

Mi-Light / MIBOXER
FUT089, FUT092, FUT096, C5
B3, T3, B4, T4, K1, FUT007, T1

Step 2: Pairing the remote control with the controller (mandatory)

Each controller can be assigned a specific remote control and a specific zone (Fig. 1, buttons 5.). If this is not done, the controller will not respond to the remote control. To do this, follow these steps:

- Connect the digital LEDs to the controller
- Turn on the controller's power and within 2 seconds of powering on, briefly press "M", and then "I" on one selected zone switch (5.). The LEDs should blink.

The controller can also be configured using the R240 Wi-Fi bridge by pairing it with a zone, then selecting "Controller configuration" in the "Edit the zone" menu and adjusting the parameters in the window. If both a remote and the bridge are used, the remote must be paired with the bridge. Remote pairing can be found in the Settings menu (gear icon in the top right corner).

Step 3: Configuration Mode

To enter the configuration settings, long press the "M" button (8 seconds).

Step 4: Strip Length

To set the desired LED strip length, use the "S+" and "S-" buttons to fill the entire LED strip with lit sections, ensuring that the flashing section reaches the end of the LED strip.

To speed up this process, use the "I" and "O" buttons on the SECOND zone switch. In this case, you will light up 10 sections at a time, instead of one at a time.

- Press the "M" button to proceed to the next step.

Step 5: Turn off the microphone

You can disable the microphone in the controller. If the LED strip's beginning lights up, it means the microphone is enabled.

- Use the "S+" button to turn the microphone on or off.
- Use the "M" button to exit the configuration.

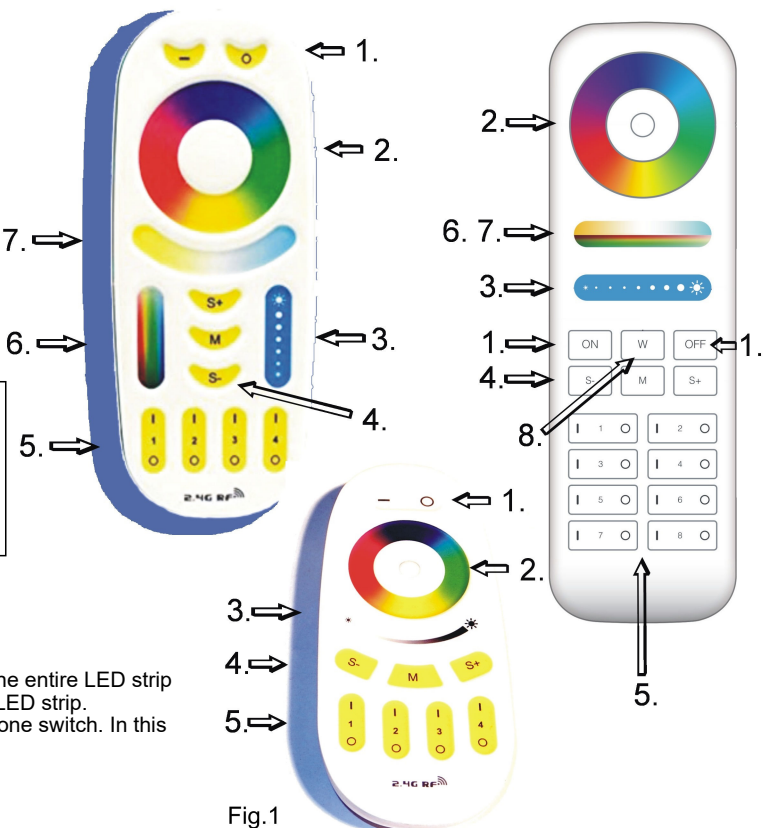

Fig.1

Using the remote control.

The main switch (1.) allows you to turn the lighting on and off. To achieve white light, press the W button (8) or press and hold "I" on the main switch or on the zone switch (5). Continuous pressing changes the white color temperature.

The color wheel (2.) is used to select the color (or set of colors) in which the light effects are created. Some effects (e.g., rainbow) do not respond to the color wheel.

The brightness slider (3.) adjusts the brightness.

The program buttons (4.), "S-" and "S+", are used to select the desired effect of folding and unfolding the light line.

The "M" button (4.) starts the animation when the light line is already unfolded. Holding this button longer will turn off the animation.

Zone switches (5.) are used to enter the control mode for a selected zone. Returning from controlling a selected zone to controlling all zones is done by touching the main switch (1.).

Slider (6.) - adjusts the color saturation.

Slider (7.) - changes the white color temperature.

Button (8.) - activates the white color. Subsequent presses will change the temperature.

WARNING! If, while using the remote control, you accidentally press a button for a zone other than the one programmed in the controller, the controller will not respond. This is intentional, as it is how zones function (allowing independent control of multiple controllers with a single remote). Accidentally pressing another zone may give the impression of a malfunction.

Deleting a remote control from the controller's memory.

- connect digital LED strips to the controller
- turn on the controller's power and within 2 seconds of powering on, briefly press "M", and then "0" on any zone switch (5.). The LEDs should blink.

Deleting all remote controls from the controller's memory.

- connect digital LED strips to the controller
- turn on the controller's power and within 2 seconds of powering on, briefly press "M", and then "0"/"OFF" on the main switch (1.). The LEDs should blink.

Restoring Factory Settings

Factory settings can be restored using a paired remote control. On the zone switch (5), briefly press "I" on the first zone FIVE TIMES, on the fourth zone TWICE. The red LED on the controller should turn off for approximately 3 seconds.

WARNING! The 4-zone remotes of the mono type B1, K1, T1, and FUT007 cannot access the configuration menu or change effects.

Pairing a B1 or T1 remote with the controller

- Connect the LED strips to the controller.
- Turn on the controller's power and within 2 seconds of powering on, press "I" three times on one selected zone switch (5.).
- The LED strips should blink.

Deleting a B1 or T1 remote from the controller's memory

- Connect the LED strips to the controller.
- Turn on the controller's power and within 2 seconds of powering on, press "0" three times on any zone switch (5.).
- The LED strips should blink.

Deleting all B1 or T1 remotes from the controller's memory

- Connect the LED strips to the controller.
- Turn on the controller's power and within 2 seconds of powering on, press OFF three times.
- The LED strips should blink.

Pairing the K1 Panel

- Connect the LED strips to the controller.
- Turn on the controller's power and within 2 seconds of powering on, press the "SET" button (9) multiple times on the back of the panel. The LEDs should blink several times – the panel has been successfully paired.

Pairing the FUT007 Remote

- Connect the LED strips to the controller.
- Turn on the controller's power and within 2 seconds of powering on, press the "I" button (5) on the zone switch panel multiple times. The LEDs should blink several times – the remote has been successfully paired.

Controller Specifications

- Power supply voltage: 5...24V
- Maximum LED current when powered through the screw terminal: 9A
- Dimensions: 60 x 84 x 30mm
- Remote control operating frequency: 2.4GHz, powered by 2 x AAA batteries
- Supported ICs (digital LEDs):
APA104, M16703A, M1824, PD9823, SK6812, SM16703, TM1803, TM1804, TM1809, TM1814, TM1824, UCS1903, UCS1909, UCS1912, UCS2903, UCS2909, UCS2912, WS2805, WS2811, WS2812B, WS2812D, WS2812F, WS2812S, WS2813, WS2814, WS2815, WS2818

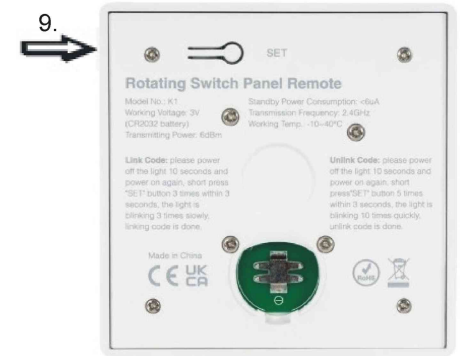
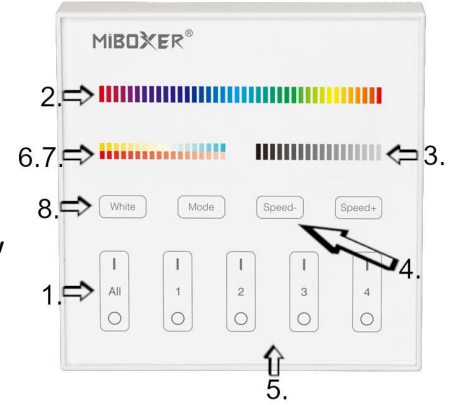
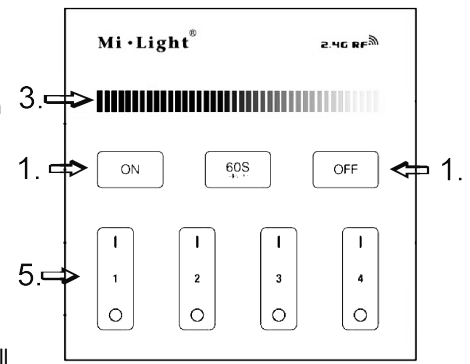

TWO LED STRIPS

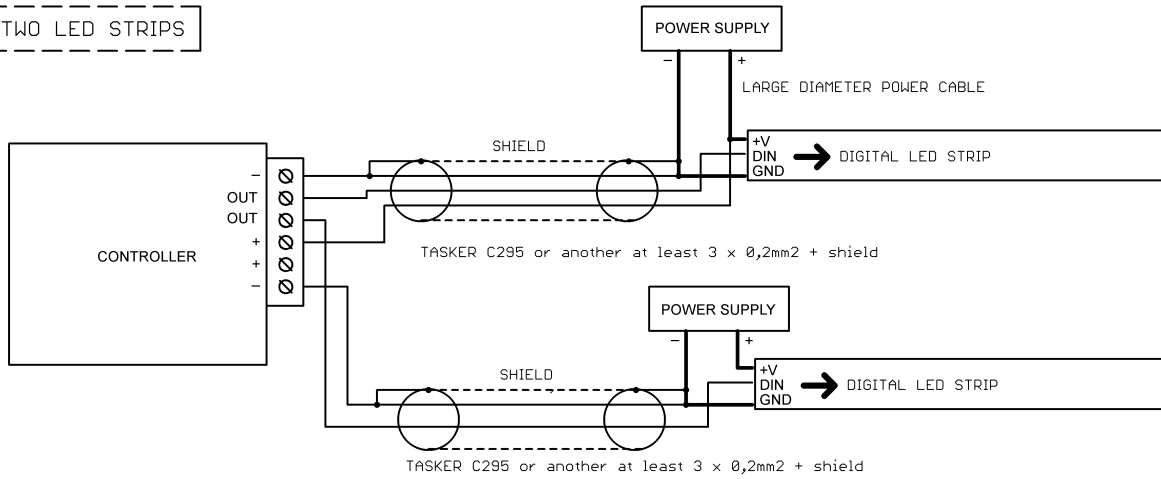

DIRECT CONNECTION

! MAXIMUM CABLE LENGTH 0,5m !

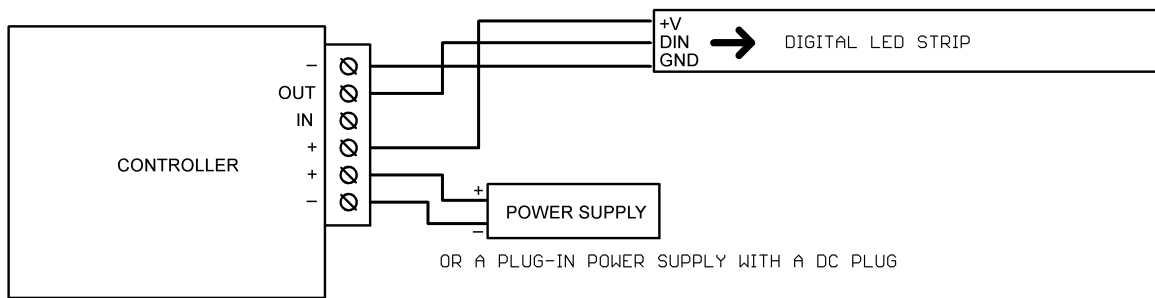

CONTROLLER POWER SUPPLY FROM A SEPARATE POWER SOURCE

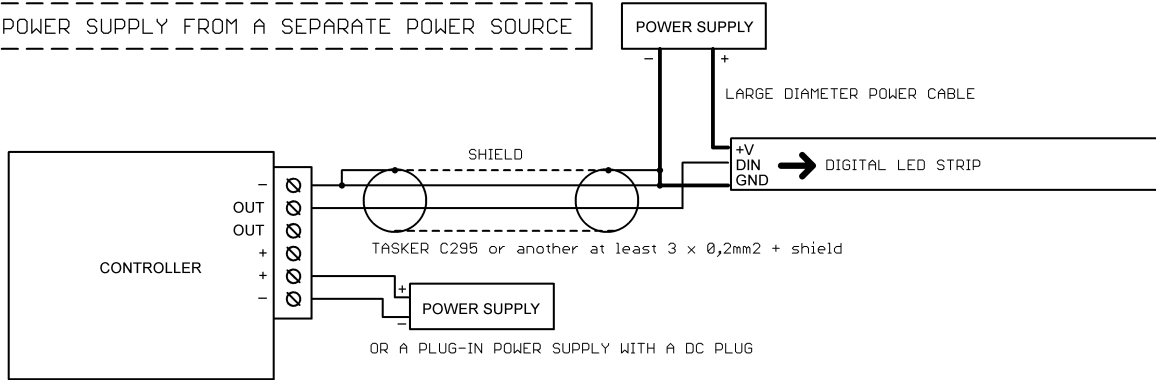

Required Operating Conditions:

- Ambient temperature: +1°C to +40°C
- Relative humidity: 30% to 75%
- The device may only be installed by a person with the appropriate qualifications.
- The LED strip control wire (connected to the device output) should not exceed 10cm. If longer wiring is needed, the control signal must be transmitted using a shielded (coaxial) cable. The responsibility for selecting the correct cable and addressing potential radio interference caused by improper wiring lies with the installer.
- The connected digital LED strip or digital LED modules must comply with applicable electromagnetic compatibility standards.
- Connect the device only when the power supply is disconnected.
- The device cannot operate near heat sources, harmful radiation, or strong electromagnetic fields.
- Clean the housing with a damp cloth, ensuring the power is disconnected.
- Do not connect the power supply if the device has visible damage.
- Protect the device from contact with water and other liquids.

Required Storage Conditions:

- Only in enclosed spaces where the atmosphere is free of vapors and corrosive substances.
- Ambient temperature: -30°C to +40°C, air humidity: 30% to 90% (non-condensing).

Device Disposal:

The device must not be discarded in regular waste bins. Unneeded or used products should be delivered to specialized recycling centers operated by municipal authorities.