



LED DALI CONTROLLER S550



The LED Controller S550 allows for the control of digital LED strips (pixels) in accordance with the international DALI specification. The device is detected as RGB+TC (color + white with temperature adjustment). It is important to note that the controller appears as **two devices** in the system, where the first allows for color setting, and the second selects the effect and its speed. While the first detected device operates according to the DALI specification, the second extends the standard and uses RGB values to select effects and animation speed.



In the second device, the red color (R) represents the effect number from the following list::

1. single color (static)	42. single color drop	82. dual color calm flow
2. rainbow	43. two-color drop	83. multi-color calm flow
3. reverse rainbow	44. multi-color drop	84. single color long stripes
4. single color spreader	45. single color spreader	85. dual color long stripes
5. two-color spreader	46. two-color spreader	86. multi-color long stripes
6. multi-color spreader	47. multi-color spreader	87. color change
7. single color cars	48. single color sequential flashes	88. single color pulsing
8. two-color cars	49. two-color sequential flashes	89. dual color pulsing
9. multi-color cars	50. multi-color sequential flashes	90. single color dense calm flow
10. strobe	51. single color wide flashes	91. lazy dots
11. single color arrows	52. two-color wide flashes	92. dual color lazy dots
12. two-color arrows	53. multi-color wide flashes	93. lazy color changing dots
13. multi-color arrows	54. all-over color flashes	94. single color running dots
14. dense rainbow	55. single-color wagons	95. dual color running dots
15. inverted dense rainbow	56. two-color wagons	96. multi-color running dots
16. single color mix	57. multi-color wagons	97. single color spill
17. two-color mix	58. single-color push-up	98. multi-color spill
18. multi-color mix	59. two-color push-up	99. multi-color pulsing
19. single color stars	60. multi-color push-up	100. fireplace
20. two-color stars	61. multi-color push-up 2	101. static lighting zone mode
21. multi-color stars	62. colorful river	102. fast flashes color
22. single color noise	63. color transitions	103. long alternating streaks (2 colors)
23. two-color noise	64. white stars on the background	104. reversing single-color streaks
24. multi-color noise	65. flowing stripe	105. reversing two-color streaks
25. single color flowing lines	66. fast rainbow	106. reversing multi-color streaks
26. two-color flowing lines	67. random effect	107. raging colors 1
27. multi-color flowing crayons	68. single-color ants	108. raging colors 2
28. color changer	69. two-color ants	109. raging color
29. reflector single color	70. multi-color ants	
30. two-color bumper	71. long single-color streaks	
31. multi-color bumper	72. long two-color streaks	
32. liquid color changer	73. long multi-color streaks	
33. single color bombs	74. spilling color to the sides	
34. two-color bombs	75. static single-color	
35. multi-color bombs	76. static two-color	
36. single color posts	77. static multi-color	
37. two-color posts	78. single color flames	
38. multi-color posts	79. dual color flames	
39. single color earthworms	80. multi-color flames	
40. two-color earthworms	81. single color calm flow	
41. multi-color earthworms		

****Effect numbers above position 109 are reserved for effects that will be added in the future.****

The green color (G) sets the effect speed, with the ranges indicating speeds:

- 0..46: minimum speed
- 47..93
- 94..140
- 141..187
- 188..234
- 235..254: maximum speed

Due to non-intuitive control that is not standard-compliant, access to the effects is only possible after setting the blue color (B) to 254. For example, if you want to use the single-color flowing lines effect in green with almost minimum speed, set the color on the first device to (0,255,0) and on the second device to, for example, (25,50,254).

For **single-color** effects, the first device sets the RGB values naturally.

For **two-color** effects, both colors are generated based on the R, G, B parameters on the first device. In this case, R is the hue of color 1, G is the hue of color 2, and B is the saturation of both colors.

For **multi-color** effects, color adjustment does not work.

Incorrect Colors - Color Settings

Digital LED strips, depending on the manufacturer, may have swapped colors. If the connected digital LED strip has a different color sequence than standard, you need to enter the strip's configuration mode by sending the following messages to the second device:

1. Off (00)
2. Off (00)
3. ON (Max) (05)
4. ON (Max) (05)
5. Min (06)
6. Min (06)

Messages should be sent with a delay of at least 2 seconds. After executing the above sequence, the strip should light up in three different colors in order. Ensure that the first three LEDs light up in the following colors: red, green, blue, changing by sending the ON (Max) command. Confirm the configuration by sending the Min (06) command.

It is important to distinguish between two types of dimming curves for the **first device**:

- logarithmic
- linear

In the case of the logarithmic scale, the LED strip lights up only at a brightness level of around 29, whereas with the linear scale, brightness works from level 1. The logarithmic scale appears to be more natural to the eye because, with the linear scale, large differences in brightness are noticeable at the beginning of the scale.

Linear control curve

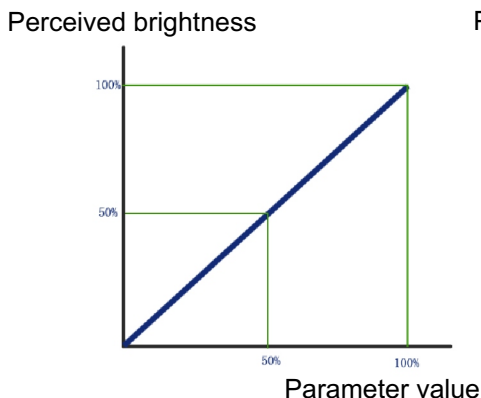

Logarithmic Control Curve

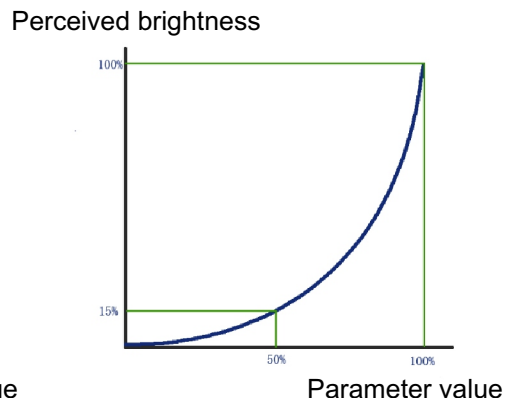

Devices can be added to groups; however, for the second device, the light level is ignored. To save a scene, the light level value must be greater than 0.

At the moment, the device supports communication according to the DALI 1 standard, meaning only 16-bit messages are supported. Compliance with DALI 2.0, and thus 24-bit messages, is planned for a future stage of the project's development.

If an RGBW strip is connected, controlling the white LED is possible by setting the white color temperature mode. If the color temperature is warmer than neutral, the red LED will also light up. For a color temperature cooler than neutral, the blue LED will light up accordingly.

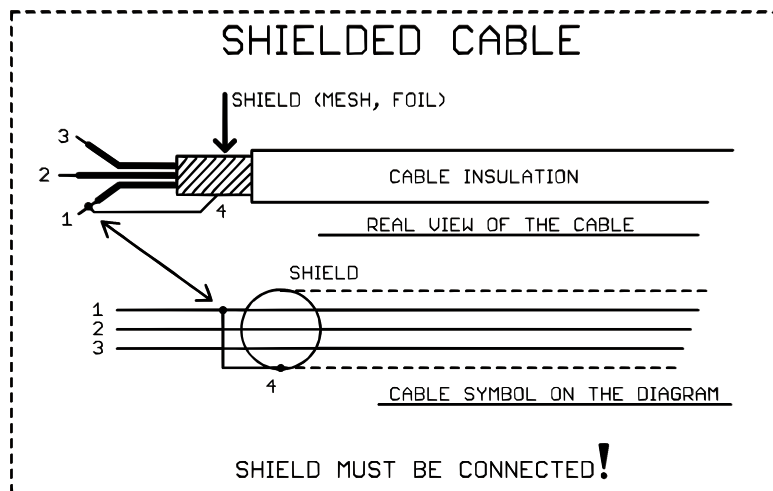
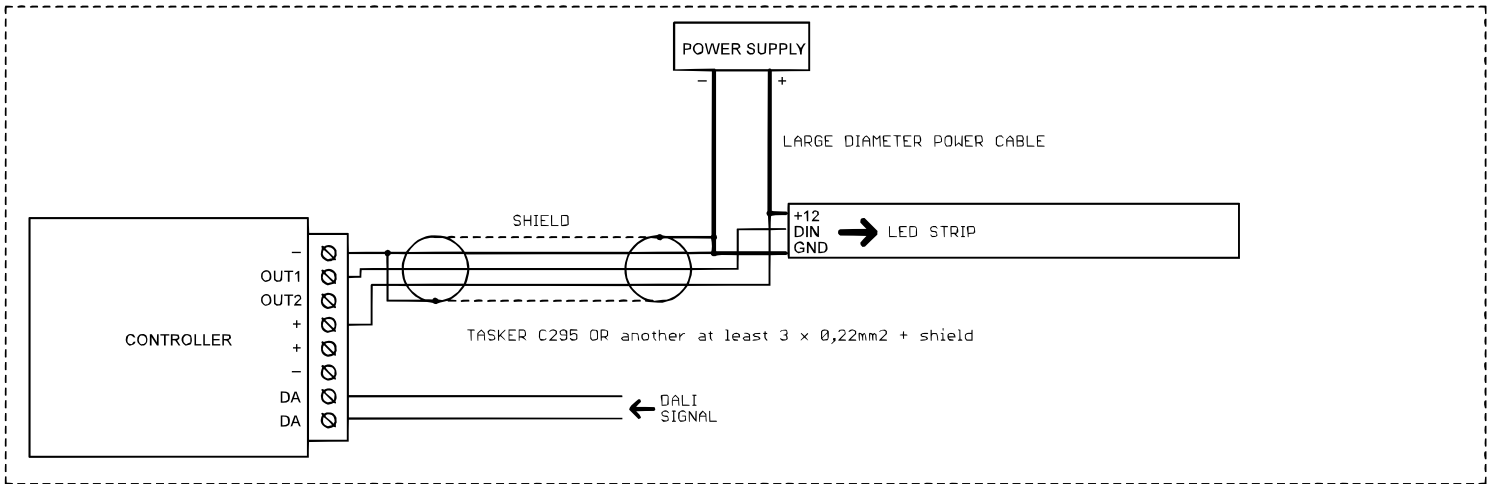

Controller Parameters:

- Communication Interface: DALI bus
- Power Supply Voltage:
Controller S550: 5...24V
- Supported ICs (digital LEDs): WS2811, WS2812S, WS2812B, WS2812D, WS2813, WS2815, WS2818, PD9823, SK6812, TM1803, TM1804, TM1809, UCS1903, UCS1909, UCS1912, UCS2903, UCS2909, UCS2912, APA104
- Maximum LED Current via Screw Terminal: 9A
For higher current demands, power should be supplied to the LEDs separately, and only the LED ground, power plus, and signal wires (OUT1, OUT2) should be connected to the controller.
- Dimensions: 60 x 84 x 30mm